



胡連精密股份有限公司

Auto World,  
We Connect  
連接車輛世界

# HULANE GROUP 胡連集團

A Professional Connectors Manufacturer  
專業連接器製造廠



Automotive Design World@www.Autoer.CN

**HL Auto Parts**  
胡連車輛零件  
= **High Level Auto Parts**  
高品質車輛零件

2017/2/20~2/24

**Hu Lane Associate Inc.**



## 內容大綱

- 公司現況 - 3
- 產品介紹 - 8
- 產品開發 -23
- 生產設備及產能狀況 -30
- 產品驗證 -34
- 全球銷售據點 -42
- 主要客戶 -44
- 發展策略 -48
- 股利政策 -51

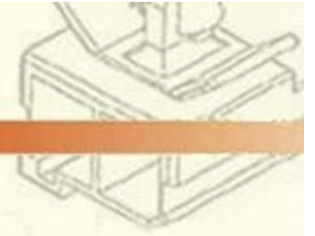

# 公司現況

- 公司概況
- 歷史沿革
- 集團組織



## 公司概況

成立年份 **1977年**

董事長 **張子雄**

總經理 **胡盛清**

資本額 **USD 32.4 百萬**

主要產品 **端子/護套/保險絲盒**





## 歷史沿革

- 1977 創立胡連企業有限公司，從事汽機車電子用端子零件製造及銷售。
- 1999 成立胡連電子(深圳)有限公司。
- 2003 於11月正式上櫃。
- 2004 成立胡連電子(南京)有限公司。
- 2006 通過TS16949 認證。
- 2007 取得 ISO 14001 認證。
- 2008 通過上海通用汽車對南京廠實驗室的認證 (GP-10)。



## 歷史沿革

2009 南京廠通過 **CNAS** 國家級實驗室認證。

2010 雷射點焊端子開發完成並獲得工業局**CITD**專案補助。

2011 開發完成電動車高電壓連接器。

胡連電子(越南)責任有限公司正式建廠完成。

公司**ERP**系統導入**SAP**系統。

2012 成立東莞胡連普光貿易有限公司。

2013 編製胡連企業社會責任報告書(中文版)。

2014 榮獲經濟部第二屆中堅企業獎。

2015 台北廠通過TAF ISO / IEC17025 國家級實驗室認證。

東莞胡連電子科技有限公司廠房落成。

2016 通過 **TÜV NORD ISO 14001:2015** 認證。

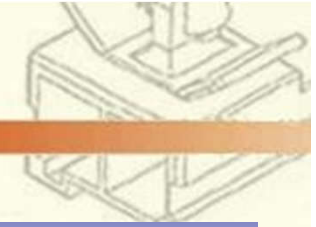

# 集團組織



## 胡連集團

### 胡連精密股份有限公司(總公司)

- 集中化管理系統(包含設計、品質控制與行銷)
- 端子製造與模具設計TERMINAL MANUFACTURING & MOLDING
- 膠盒製造與模具設計HOUSING MANUFACTURING & MOLDING

### 胡連精密股份有限公司-香港分公司

- 端子與膠盒銷售

### 東莞胡連電子科技有限公司

- 端子製造與模具設計TERMINAL MANUFACTURING & MOLDING
- 膠盒製造與模具設計HOUSING MANUFACTURING & MOLDING
- 端子/膠盒/保險絲盒...等產品的銷售及倉儲物流中心 SALES & LOGISTICS CENTER

### 胡連電子(南京)有限公司

- 端子製造與模具設計TERMINAL MANUFACTURING & MOLDING
- 膠盒製造與模具設計HOUSING MANUFACTURING & MOLDING
- 橡膠產品/保險絲盒/板端連接器設計生產 RUBBER PARTS / FUSE BOX / WAFER CON. MANUFACTURING AND DEVELOPMENT

### 胡連電子(越南)責任有限公司

- 端子製造與模具設計TERMINAL MANUFACTURING & MOLDING
- 膠盒製造與模具設計HOUSING MANUFACTURING & MOLDING
- 端子&膠盒銷售



# 產品介紹



- ▶ 高速沖壓端子
- ▶ 複合式沖壓端子
- ▶ 雷射點焊端子
- ▶ 射出成型護套件
- ▶ 橡膠/矽膠件
- ▶ PVC護套件
- ▶ 電動車接插件
- ▶ 繼電器-保險絲盒





儀表類

Instrument Panel

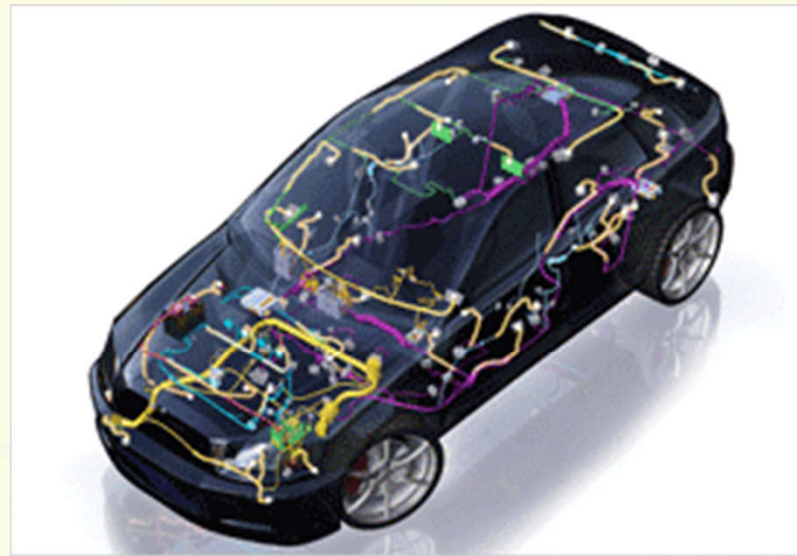
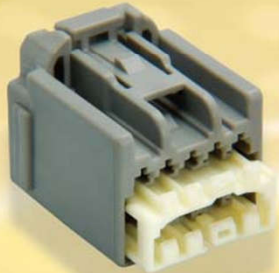

保險絲類 Fuse



板端類

Wire to Board connector

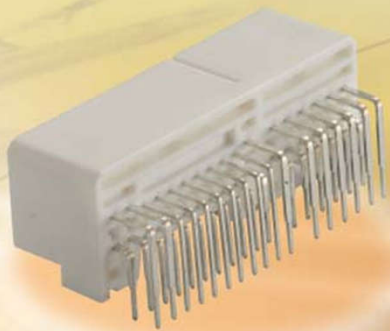

電子控制燃料噴射系統類

EFI(Electronic Fuel Injection Systems)



車燈類

Automobile Lamp



液化瓦斯/  
天然瓦斯轉換器類

LPG/CNG





# 高速沖壓端子Terminal





# 複合式端子

產品以兩種材質製成

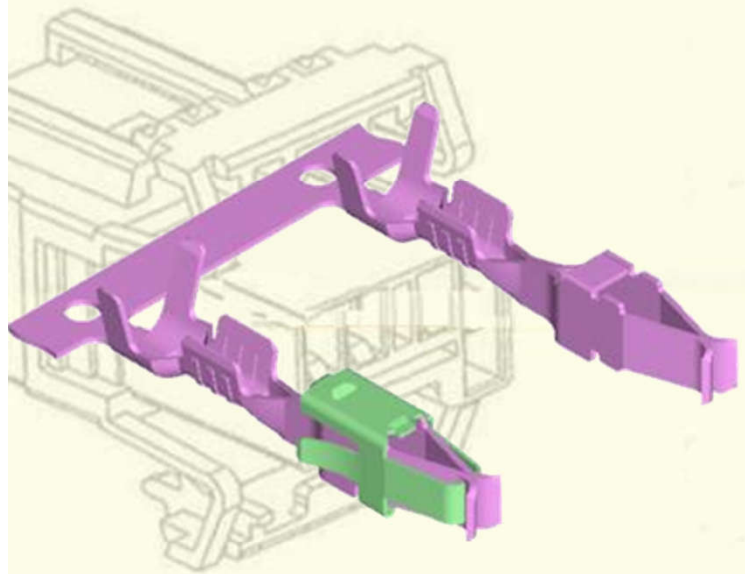

外扣形式

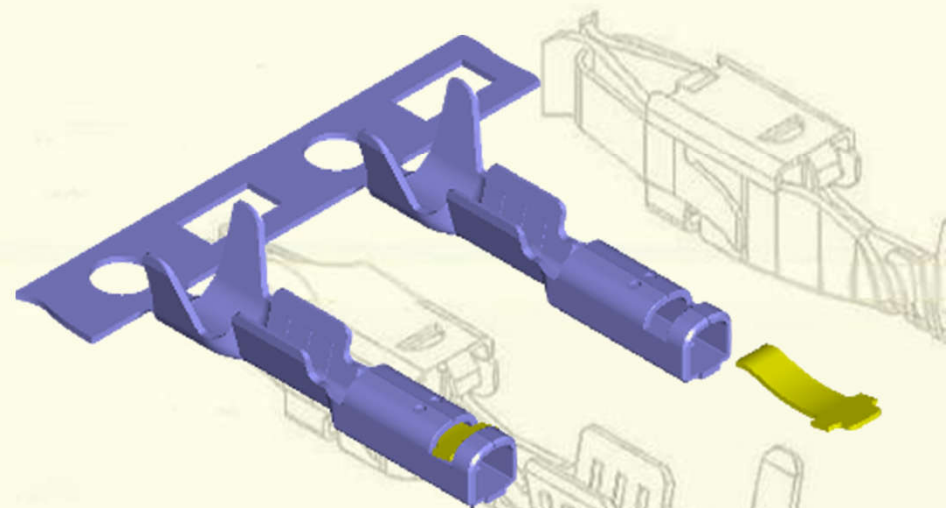

內鑲形式



# 雷射點焊端子 Laser Welding Terminal

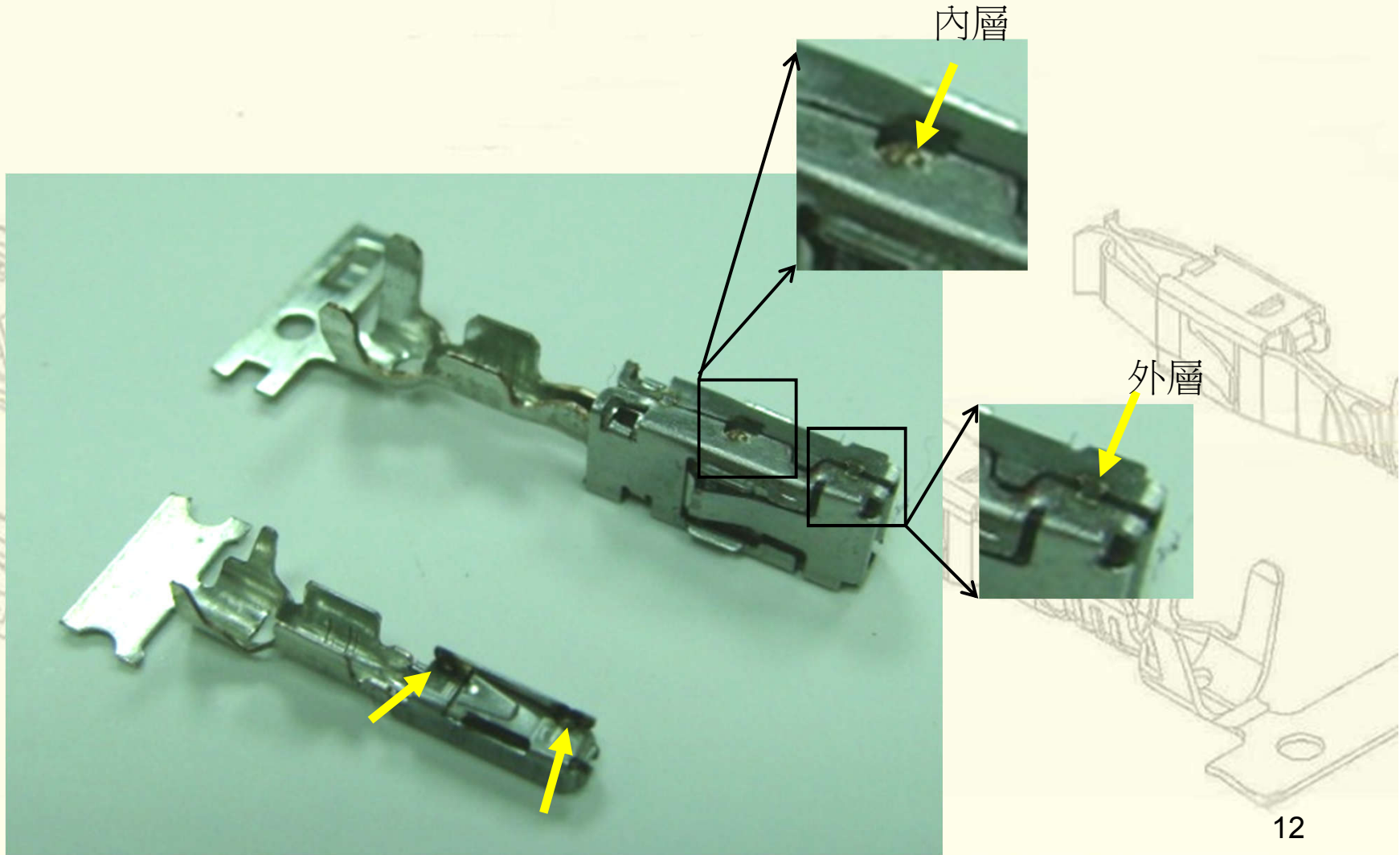



射出成型  
護套件  
Housing

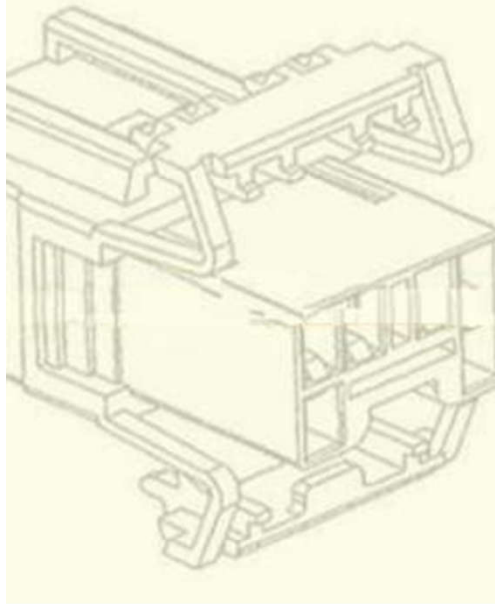

DLS02FB



DLE18FW



DLJ04FGY



MID09FY



SSA02FB



DLK02FY





# 橡膠 / 矽膠件 Rubber/Silicon Parts



## PVC 護套件





# 電動車接插件

## EV Connector

直流電DC output 4pin  
(2 Power 2 Signal , shield)

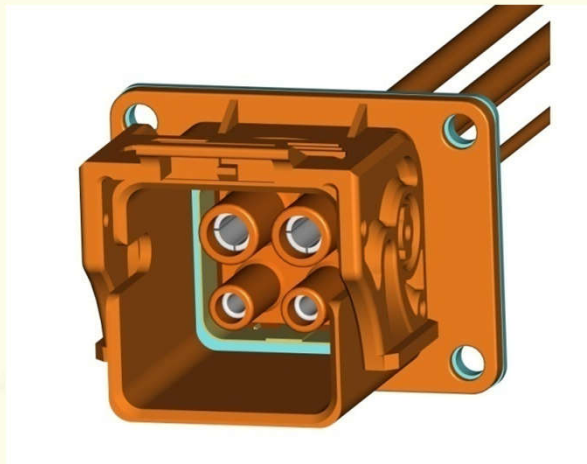
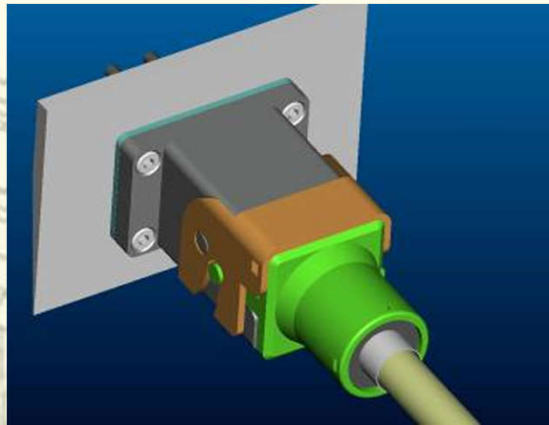

交流電AC input 3 Power pin

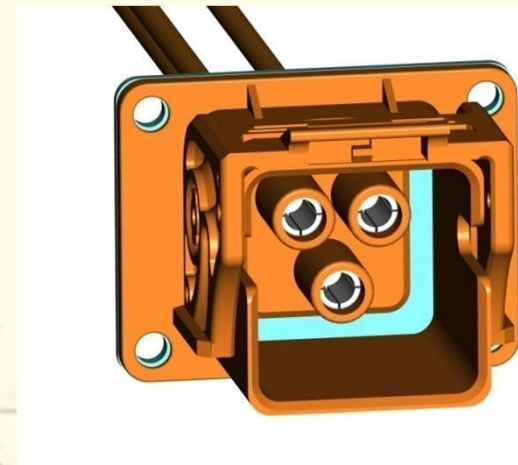

交流電AC input 5pin  
(3 Power 2 Signal)



電動摩托車連接器

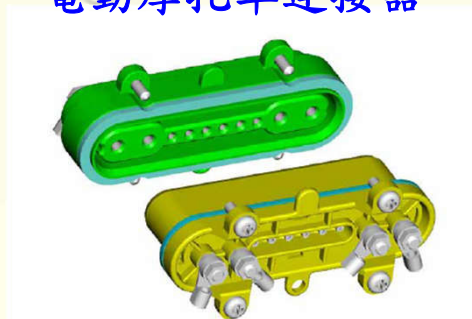

高電壓連接器  
(1 Power , shield)

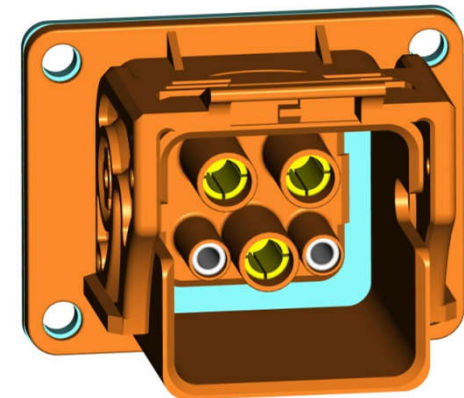



# 板端/PC 板接插件

## Wire to Board / Power Connector

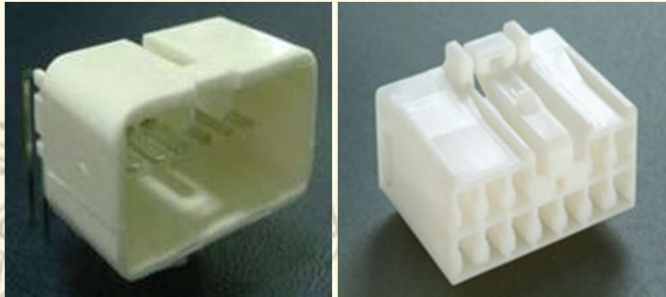

PM12MW  
TTL12FW



CDB10MB

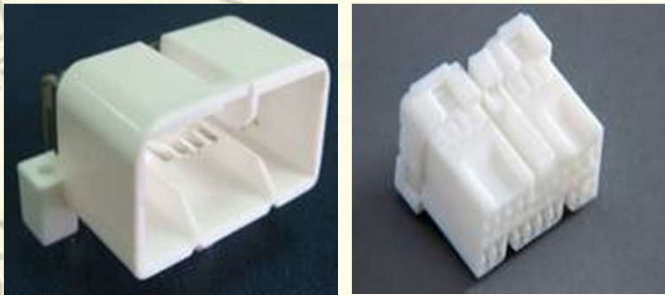

PM15MW  
TR15FW



KYMC36MBK



HV16HW  
HV16FW



TKH34MW





# 保險絲盒 FUSE BOX

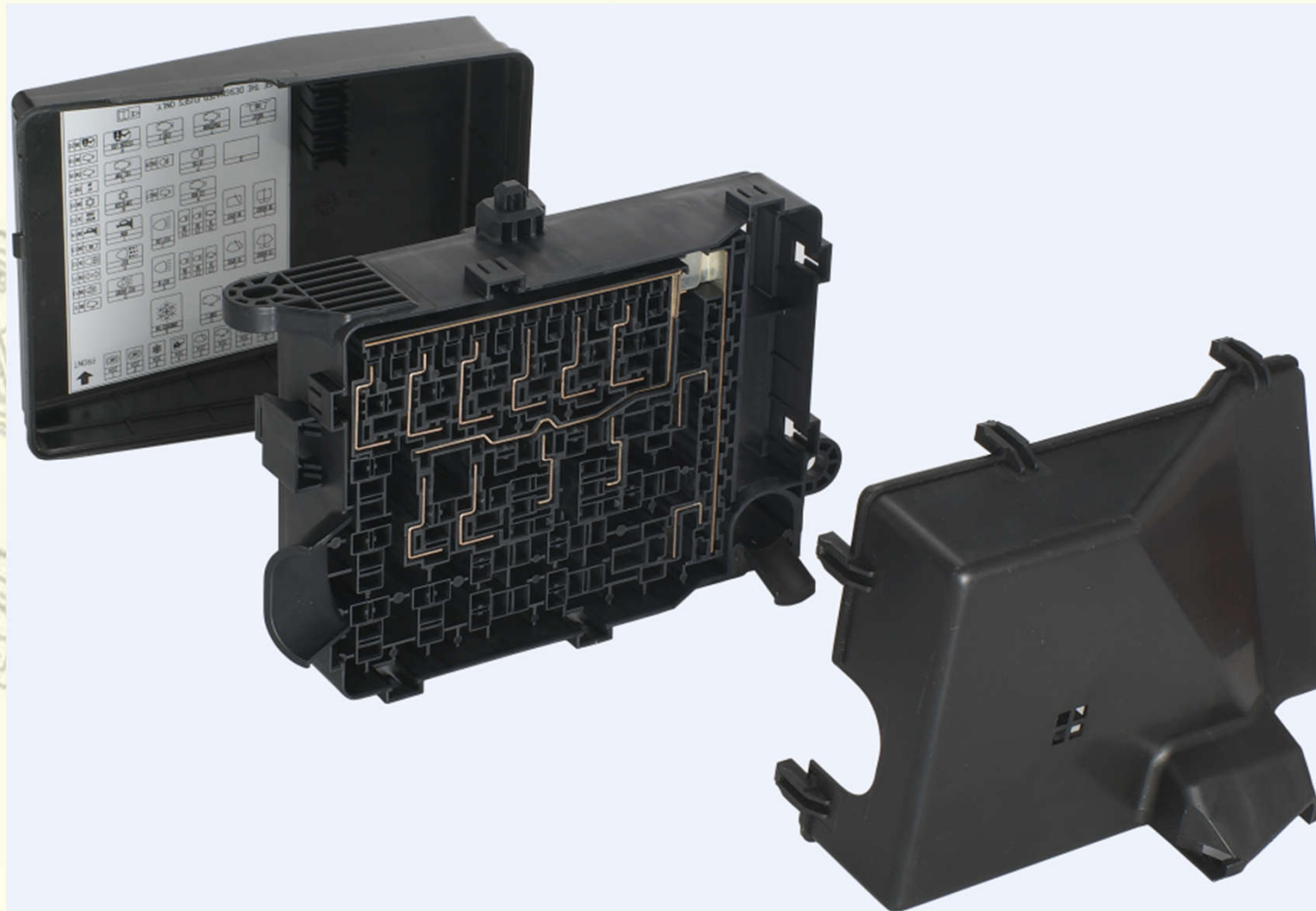



# 繼電器 RELAY BOX





眾泰乘用車 3845B9013AAB  
(33FBCFB9FBKM)

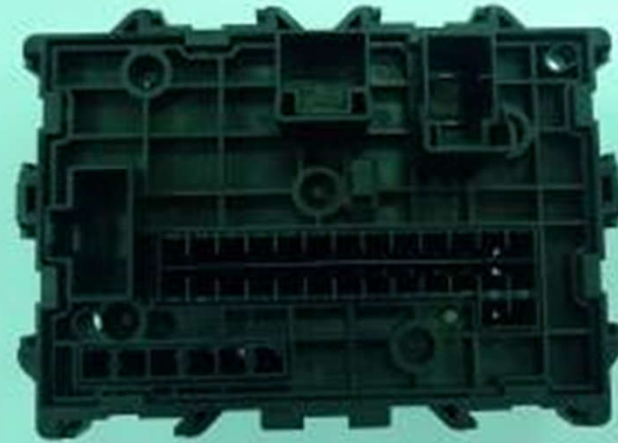

鄭州日產皮卡 383272011AAB  
(33FBCC72FBK)

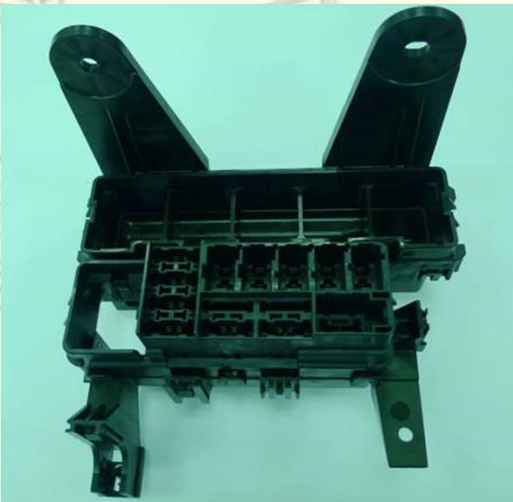

鄭州日產皮卡 384524011RMB  
(33FBCB24FBK)



東南乘用車 3845E0012AAB  
(33FBCDE0FBK)



# 汽車產業供應鏈 The automotive supply chain

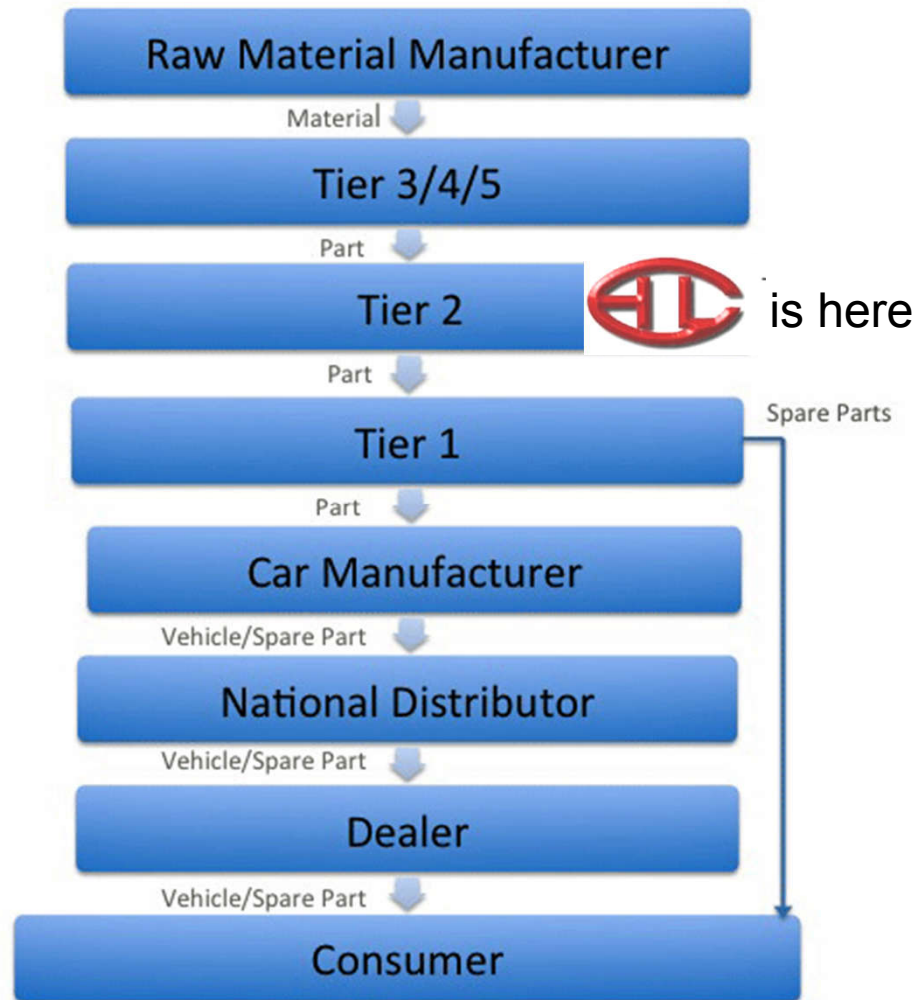



## Ranking of Major Global Automotive Wiring Harness Companies by Revenue, 2009-2015

USD mln	2009	2010	2011	2012	2013	2014	2015
SUMITOMO ELECTRIC	6,384	7,974	8,958	9,980	9,661	10,579	8,989
YAZAKI	7,548	9,808	11,236	12,220	11,720	12,092	11,390
DELPHI	3,022	4,330	5,117	5,286	6,024	6,516	6,300
LEONI	1,531	2,166	2,688	2,824	3,035	3,190	3,037
FURUKAWA ELECTRIC	914	940	980	1,127	1,350	1,308	1,173
LEAR	1,090	1,448	1,819	1,810	2,170	2,453	2,552
Coroplast	400	412	408	360	330	302	270
FUJIKURA	656	753	899	1,097	1,150	1,230	1,170
YURA	860	1,145	1,150	1,208	1,360	1,408	1,450
Kromberg & Schubert	350	370	418	410	400	430	390
PKC	263	419	635	1,199	1,174	1,027	940
Others	1,518	1,506	1,638	2,008	2,260	2,180	2,060

Source: *Global and China Automotive Wiring Harness Industry Report, 2015* by  
ResearchInChina



### 2013-2014全球主要汽車連接器製造廠營收排名

	2013	2014E
TE	4110	4568
YAZAKI	2246	2508
DELPHI	1420	1460
SUMITOMO	560	608
Molex	688	716
Amphenol	554	680
JAE	530	520
KET	413	460
JST	360	350
Kyocera	260	250
Rosenberg	185	180
HIROSE	180	185
Hulane	94	107

資料來源：ResearchInChina,全球和中國的汽車用連接器產業報告,2014-2015



# 產品開發



- 研發人力資源
- 設計輔助工具及應用
- 產品開發管理系統
- 模具開發能量

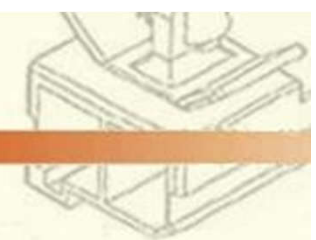

# 研發人力資源

	產品工程 Product Engineer	模具開發 Mold Development Engineer	設計輔助軟體 Engineering Aid software
集團合計	63	142	<p><b>2D CAD</b> : Auto CAD /KeyCreator /LifeCAD</p> <p><b>3D CAD</b> : CATIA/ UG/ Pro-E /SolidWork+C&amp;G Press</p> <p><b>CAE</b> :</p> <p>模流分析 : Moldex 3D/ SIGMASOFT</p> <p>結構力學分析 : ABAQUS</p> <p>熱傳分析 : FloEFD</p>





# PLM產品生命週期管理系統

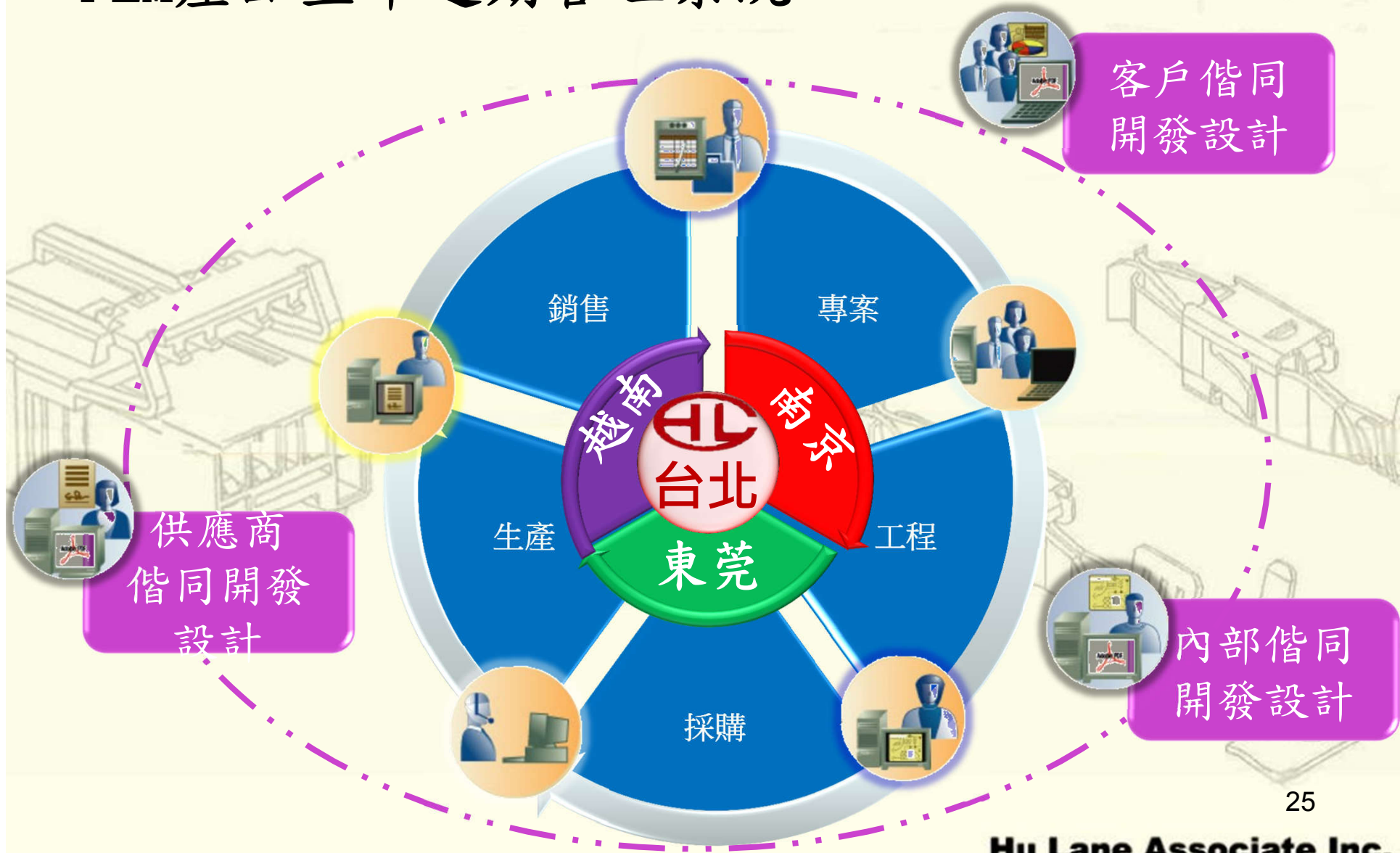



# 模具管理系統 Mold Management System

胡連精密股份有限公司 Hu Lane Associate Inc.

功能選單

- 系統基本選項
- 模具庫存進出
- 模具資料記錄
- 備品零件管理
- 模具資料查詢
- 基本資料建立
- 系統權限管理
- OEE表單資料
- 系統登出離開
- 產品資料查詢
- QDS表單資料

即時資訊

- 模具資料不足 (1271筆)
- 保養計畫設定 (0筆)
- 出庫模具數量 (145筆)
- 維修保養模具 (284筆)
- 申請停用模具 (0筆)
- 備品零件不足 (0筆)

模具訊息總覽

- 待保養模具 (0筆)
- 出庫中模具 (0筆)
- 故障模具紀錄 (143筆)

出庫單號	預計歸還日期	模具號碼	出庫原因	可否入庫
1 MO2008100128T	2008/08/31	620701A	生產使用	尚未保養
2 MO2008100134T	2008/08/31	892403	生產使用	尚未保養
3 MO2008100126T	2008/08/31	622500	生產使用	尚未保養

更多...

模具號碼	模具類別
1 BJ-2ASP	塑膠模
2 C06MW(新)	塑膠模
3 CB02MW	塑膠模

更多...

- 透過模具生產次數的記錄，管控模具生命週期（模具壽命管理）
- 透過維修履歷的建立，將經驗知識轉為模具設計之參考（DFMEA 的具體實現）
- 透過生產模數的統計，早期準備模具備品（即時生產交貨的具體實現）



# 高速沖壓模具

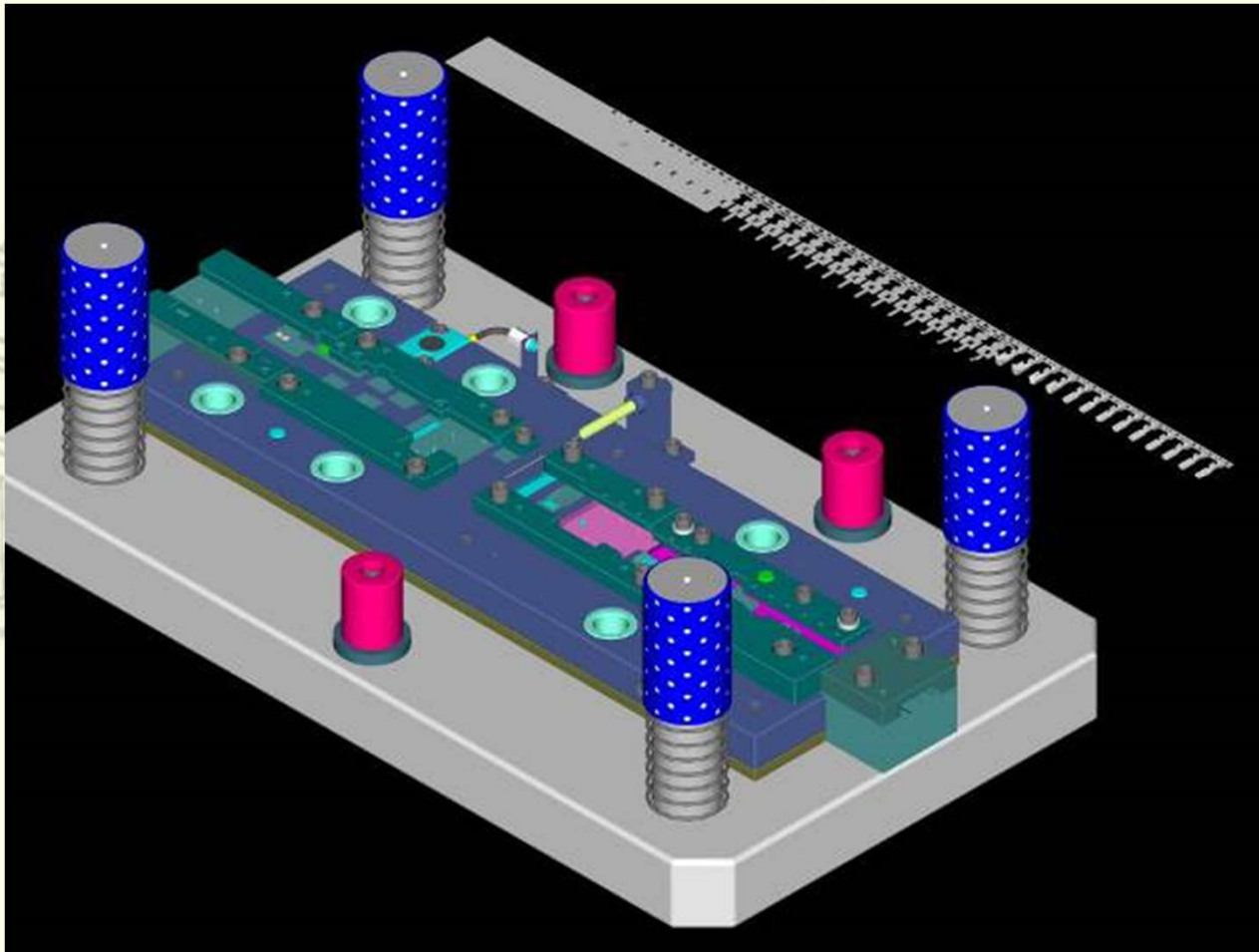

開發能量：  
**20 組/月**



# 塑膠射出成型模具

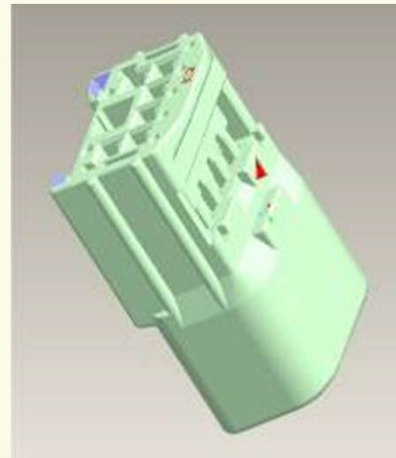
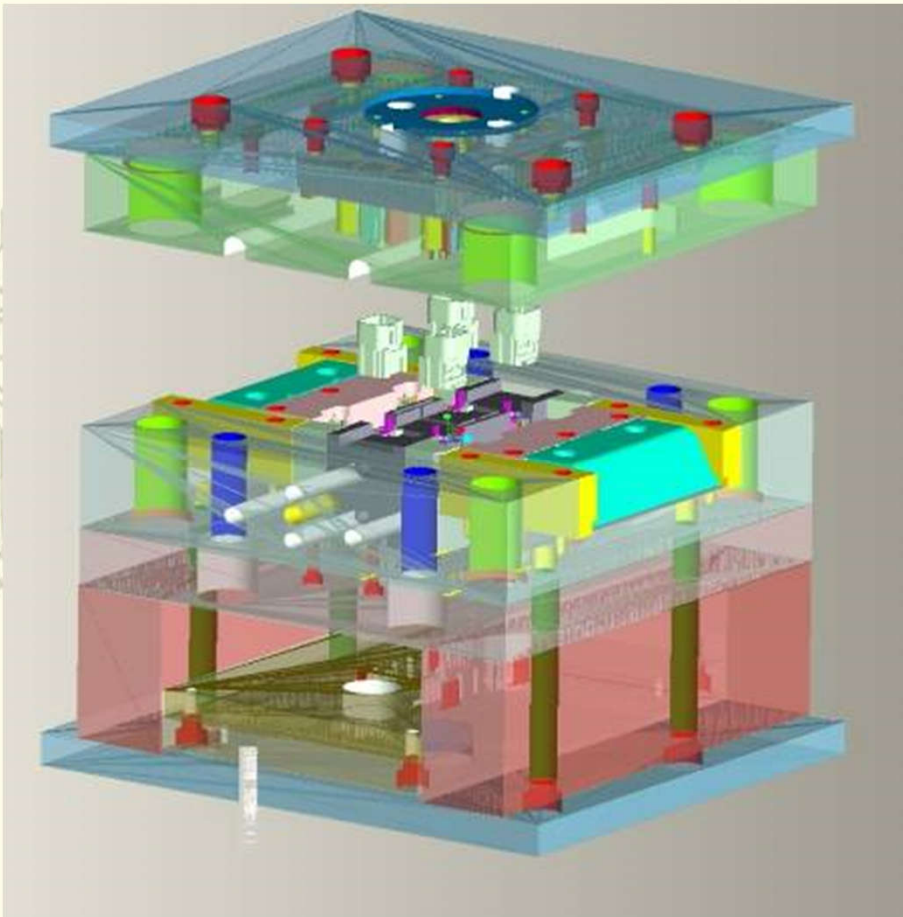

開發能量: **30** 組/月



# 產品發展策略

產品發展  
與  
技術



時程

2016	2017	2018	2019	2020	2021~
------	------	------	------	------	-------



# 生產設備及產能狀況

- 台北廠及總公司
- 深圳廠
- 南京廠
- 越南河內廠
- 東莞廠



# 各廠據點

中國南京廠  
員工：633 人

台灣台北廠  
員工：367 人



越南河內廠  
員工：73 人



中國東莞廠  
員工：514 人

合計員工數：1,587 (2017/1/23, 含香港分公司)



# 生產設備

高速沖壓機

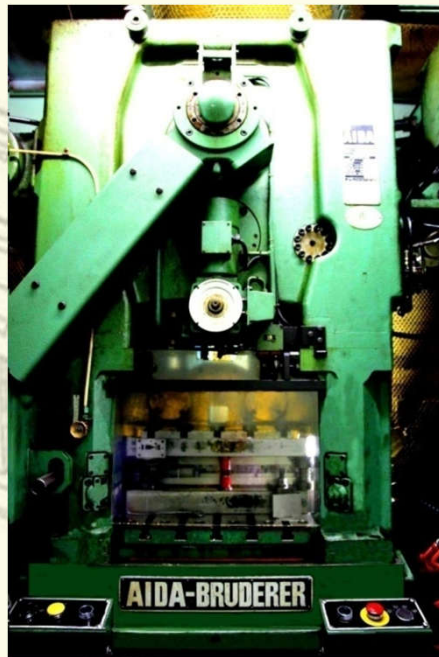

**AIDA-BRUDERER BSTA25**

產能	25 噸 (ton)
行程長度	19 mm
運轉能力	1240 spm

自動成型射出機



**FANUC ROBOSHOT α-S100iA**

自動組裝機  
(機械手臂)



自動插接針機



**TOYO 100Si-100-6**







類別	沖床		射出機		橡膠機		總產能佔比%
	機台數	佔比%	機台數	佔比%	機台數	佔比%	
廠區別							
台北廠	37	48%	41	23%	0	0%	29%
南京廠	17	22%	101	57%	13	76%	48%
越南廠	4	5%	15	8%	0	0%	7%
東莞廠	19	25%	21	12%	4	24%	16%
合計	77	100%	178	100%	17	100%	100%

計算原則：已投產之機臺(統計到2017年1月底)。



# 產品驗證

## ▶ 南京產品驗證實驗室

- ✓ 可從事 US-CAR, MES, NDS, GB, GME 實驗
- ✓ 經上海通用汽車認證通過 Certified by SGM
- ✓ 通過 ISO17025/CNAS 國家級實驗室認證

## ▶ 台北產品驗證實驗室

- ✓ 可從事全套 MES, NDS, Mitsubishi 實驗
- ✓ 經德爾福及日產汽車認證通過
- ✓ 通過 ISO17025/TAF 國家級實驗室認證



# 實驗室

恆溫恆濕機



線上 LCD 自動檢測機



3D 實物列印機



耐振動試驗機



臥式投影機

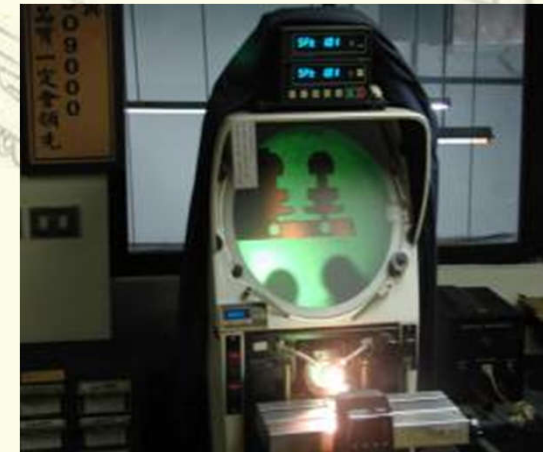



# 實驗室

耐臭氧試驗機



耐塵試驗機



鹽霧試驗機



耐油污試驗機



耐雨水及高壓水柱衝擊試驗機





# 實驗室



硬度試驗機

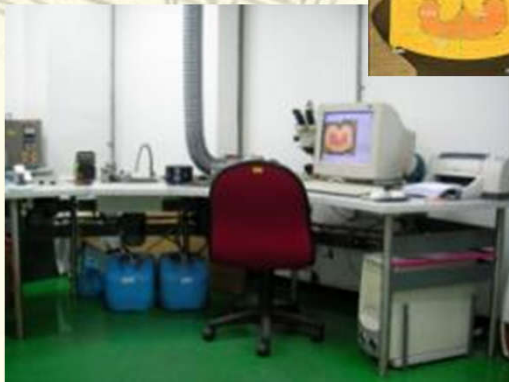

壓著金相試驗組

XRF元素分析儀



材料試驗機





# 實驗室認證

## ISO 17025 /TAF National Lab Certi.

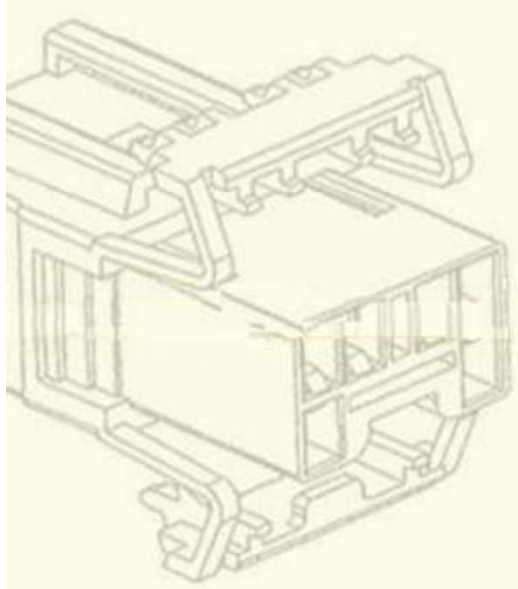
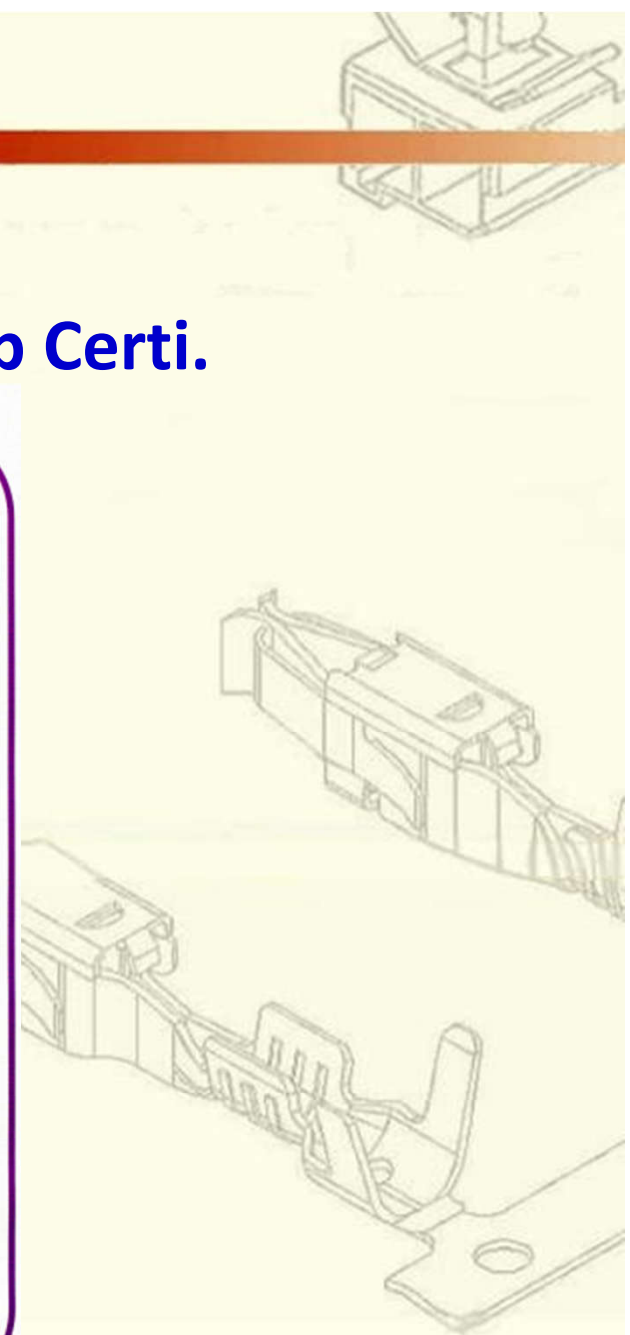



# 實驗室認證

## ISO 17025 /CNAS National Lab Certi.





# 實驗室認證--上海通用



## GP-10 认可证书

### GP-10 ACCREDITATION

胡连电子(南京)有限公司

HU LANE ELECTRONIC(NANJING) CO., LTD

有效期:2017年4月5日 地址:江苏南京江宁空港工业园来凤路38号 邮编:211113 授权签字人:李嵩 电话:025-52774425 证书编号:L162  
Valid to:Apr. 5, 2017 Address:N.38 Laifeng Road Airport Industrial Park,Lakou Town,Nanjing Zip Code:211113 Authorized Signatory:Li Song Phone:025-52774425 Certificate Number:L162

鉴于实验室已成功通过SGM GP-10的评估,我们对下列试验进行认可:

In recognition of the successful completion of the Shanghai GM GP-10 evaluation process, accreditation is granted to this laboratory to perform the following types of tests.

#### 认可范围

#### SCOPE OF ACCREDITATION

SAE/USCAR-2-2013	Terminal-Mechanical Tests	GMW3191-2012	Crack Corrosion
5.2 端子-机械试验	Terminal-Electrical Tests	4.2.1 裂缝腐蚀	Crimp Weld Integrity
5.3 端子-电气试验	Terminal-Connector Insertion/Retention and Forward Stop Force	4.2.2 压接完整性	Terminal to Terminal Engagement Force
5.4.1 端子-连接器插拔力	Connector-Connector Mating/Unmating/Retention/Lock Deflection Forces(Not-assist)	4.2.3 端子与端子插入力	Terminal to Connector Engagement Force
5.4.2 连接器-连接器插拔力(无辅助机构)	Connector to Connector Mate/Unmate Forces(Mechanical Assist)	4.2.4 端子与连接器插入力	Terminal from Connector Extraction Force
5.4.3 连接器-连接器插拔力(带辅助机构)	Polarization Feature Effectiveness	4.2.5 端子与连接器拔出力	Terminal Cavity Polarization
5.4.4 极化功能有效性	Miscellaneous Component Engage/Disengage Force	4.2.6 端子腔极性功能	Terminal Bend Resistance
5.4.5 其他元件接合分离力	Vibration	4.2.7 端子弯曲测试	Connector to Connector Engagement Force
5.4.6 振动试验	Connector Drop Test	4.2.8 连接器与连接器插入力	Terminal Position Assurance(TPA)
5.4.8 连接器跌落试验	Cavity Damage Susceptibility	4.2.9 端子位置的保持	Connector Position Assurance(CPA)
5.4.9 插入孔损伤敏感性	Connector Mounting Feature Mechanical Strength	4.2.15 连接器位置的保持	Connector Seal Retention-Mated Connector
5.4.11 连接器装配功能机械强度	Mechanical Assist Integrity	4.2.16 连接器防水部件保持-嵌合连接器	Connector Seal Retention-Unmated Connector
5.4.12 机械辅助装置	Isolation Resistance	4.2.17 连接器防水部件保持-未嵌合连接器	Locked Connector Disengagement Force
5.5.1 绝缘阻抗	Thermal Shock	4.2.18 连接器拔出力(带锁)	Unlocked Connector Disengagement Force
5.6.1 热冲击	Temperature/Humidity Cycling	4.2.19 连接器拔出力(不带锁)	Maximum Current Rating
5.6.2 温度/湿度循环	High Temperature Exposure	4.3.1 最大额定电流	Dry Circuit Resistance
5.6.3 高温暴露	Fluid Resistance	4.3.2 接触电阻	Voltage Drop
5.6.4 耐液体	Submersion	4.3.3 电压降	1008-Hour Current Cycling
5.6.5 浸液	Pressure/Vacuum Leak	4.3.4 电流循环	Isolation Resistance
5.6.6 压力/真空泄漏	Head PIN Retention	4.3.5 绝缘电阻	Dielectric Strength
5.7.1 PIN保持力	Electrical Performance	4.3.6 击穿强度	Thermal Aging
SAE/USCAR-15-2010	Mechanical Performance	4.4.1 热老化	Thermal Shock
4 电学性能	Environmental Performance(Except for Ozone Resistance)	4.4.2 热冲击	Humid Heat Cyclic
5 力学性能		4.4.3 湿热循环	Humid Heat Constant
6 环境性能(除臭氧试验)		4.4.4 湿热恒定	Heavy Duty Test
		4.4.5 高载测试	Corrosion-Unsealed Connection Systems
		4.4.7.4.1 盐雾测试-非密封连接器	Vibration with Thermal Cycling
		4.4.8 复合温度振动	Water Submersion
		4.4.9 浸水测试	Pressure/Vacuum Leak
		4.4.10 压力/真空泄露	Fluid Resistance
		4.4.12 耐液体测试	Terminal Push Out Force
		4.5.2 端子推出力	



审核 Audit: 孙峰 批准 Approval: 李嵩  
日期 Date: 2015-6-17

上海通用汽车有限公司采购部  
Shanghai General Motors Co., Ltd. Purchasing Department





# 品質系統

胡連精密股份有限公司

品質系統圖

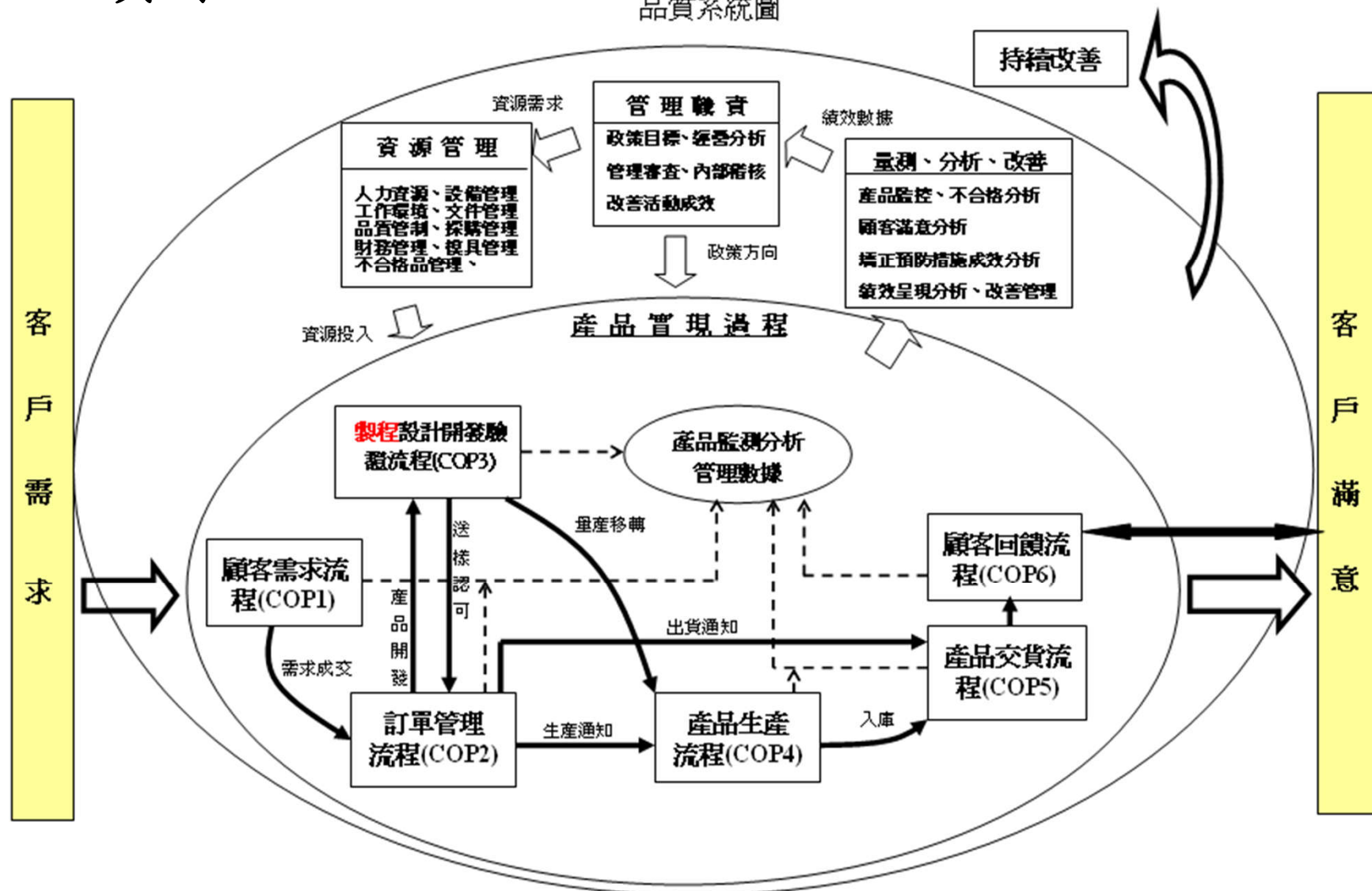



# 全球銷售據點



- 台灣總公司
- 中國銷售點
- 東南亞銷售點
- 歐洲代理



# 全球銷售據點

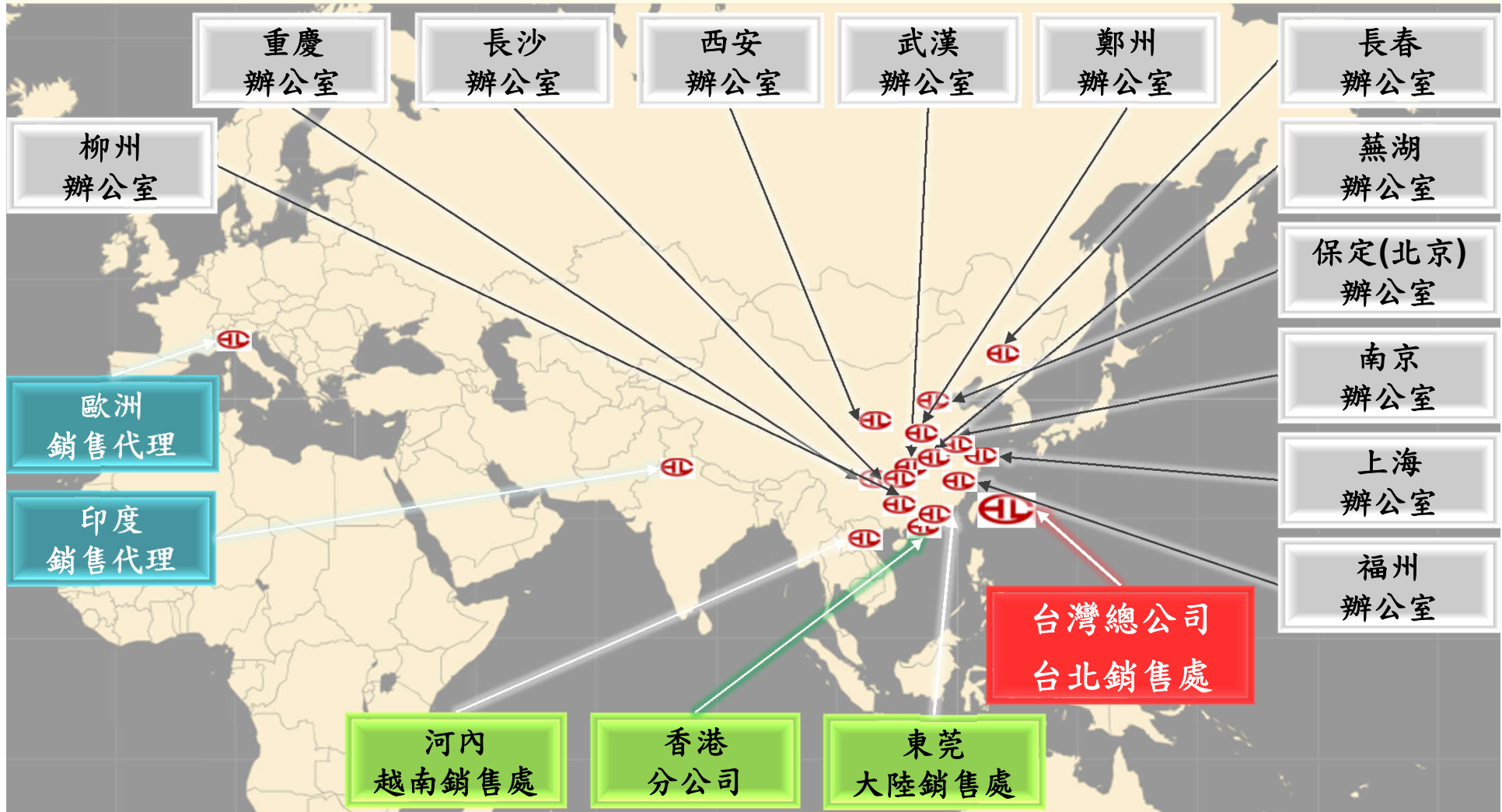



# 主要客戶



- 中國市場
- 台灣市場
- 國外市場



# 中國市場

胡連集團

汽車



電動車



機車



其他





# 台灣市場

胡連集團

汽車



機車



電動車

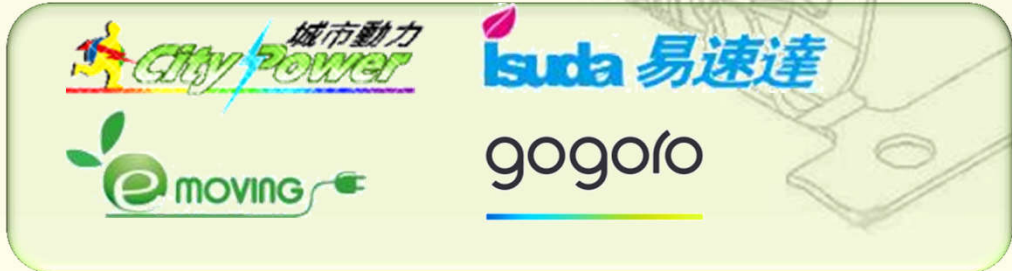



# 其他市場

胡連集團

汽車



機車





# 發展策略

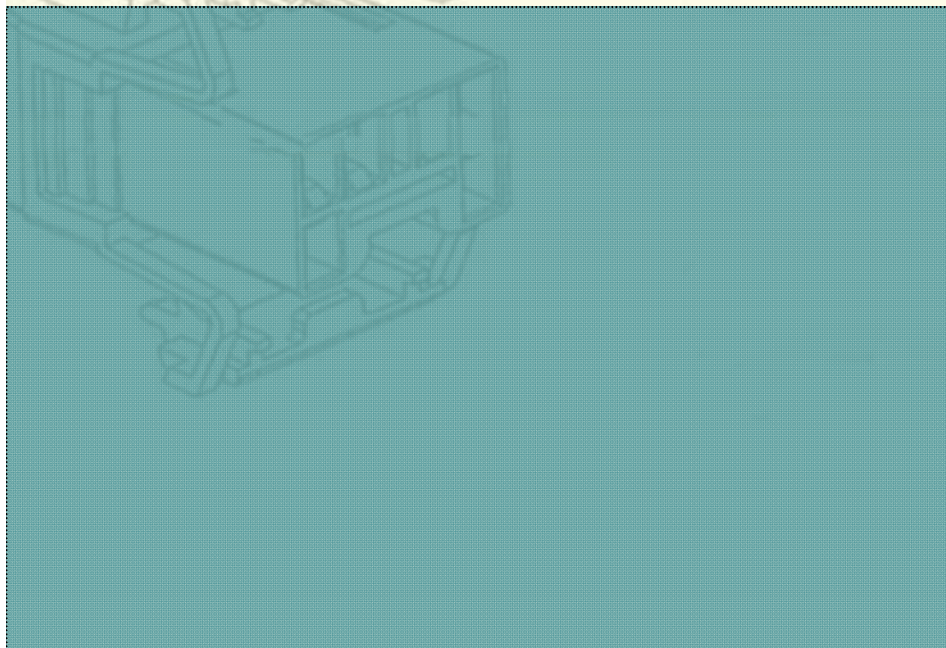





## 地區別銷售佔比

區域\年度	2012	2013	2014	2015	2016/1Q~3Q
亞洲—中國	50%	54%	54%	61%	64%
亞洲—伊朗	2%	3%	6%	4%	4%
亞洲—越南		5%	4%	4%	4%
亞洲—以上國別以外地區	36%	28%	23%	21%	18%
其他—亞洲以外	12%	10%	13%	10%	10%
總計	100%	100%	100%	100%	100%



### 區域別 / 國別汽車銷量(輛)

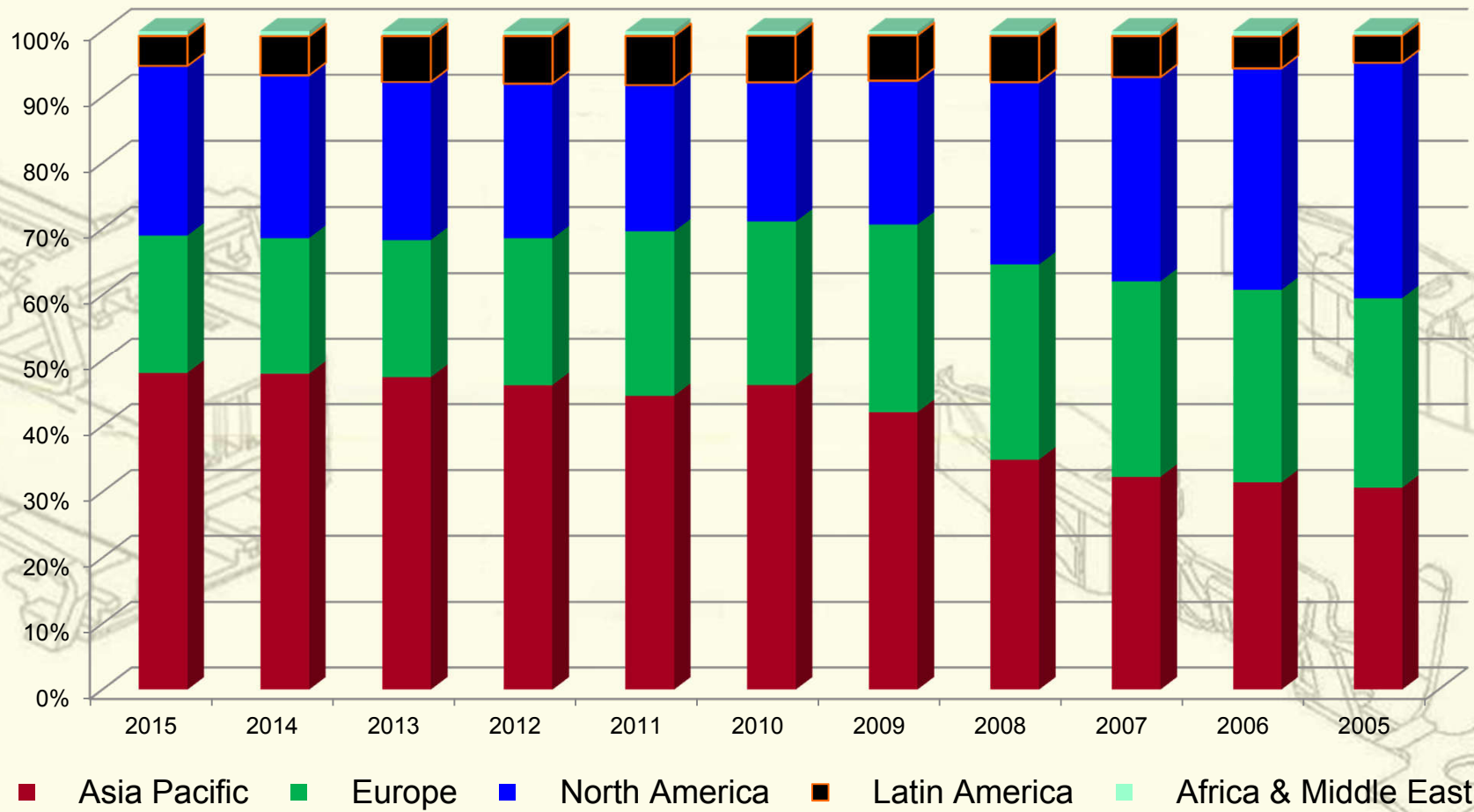



# 股利政策

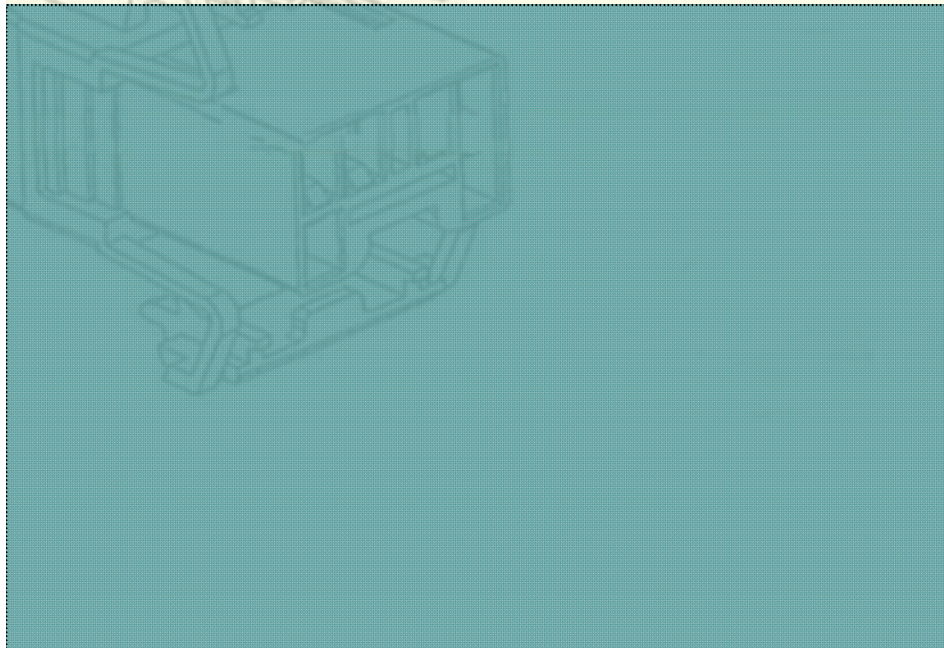



項次 \ 年度	2012	2013	2014	2015	2016/1Q~3Q
稅前	5.87	7.96	9.81	10.56	7.34
稅後	4.77	6.31	8.00	8.25	5.66
股利分派	3.3	6	5.6	5.6	--
現金	3.3	6	5.6	5.6	--
股票	0	0	0	0	--
股利分派率	69%	95%	70%	68%	--



## 長期發展策略

- ▶ 達成成長目標與穩定的股利政策，維護股東權益。
- ▶ 持續與全球一階供應商進行系統性整合開發合作。
- ▶ 全力開發新興國家市場。
- ▶ 持續新產品的設計研發及汽車線束相關零組件整合開發。



感謝您~

